

# FTA550F JOCKEY PUMP CONTROLLERS

## STANDARD SUBMITTAL PACKAGE

***Firetrol***<sup>®</sup>

NOTE: The drawings included herein are for standard controllers.  
Actual "as built" drawings may differ from those seen here.

# FTA550F XG Jockey Pump Controllers

## Product Description



**Description**—Firetrol® FTA550F XG Jockey Pump Controllers are intended for use with fire pump systems. They are used for pressure maintenance in fire pump installations to prevent unnecessary operation of the main fire pump.

**Approvals**—Firetrol jockey pump controllers are listed by Underwriters’ Laboratories, Inc., in accordance with UL508A, Standard for Industrial Controls, and CSA, Standard for Industrial Control Equipment. They are built to meet or exceed the requirements of the approving authorities as well as NEMA and the latest edition NFPA 70, National Electrical Code.

**Standard Features**—The following are included as standard with each controller:

- NEMA Type 2/12 (IEC IP22/IP54) Polycarbonate enclosure (UL50E Construction)
- Horsepower rated motor circuit protector and starting contactor
- Suitable for use as service equipment
- HAND-OFF-AUTO selector switch
- Minimum run timer
- On-Delay timer
- Pump Restart Timer
- Control circuit transformer with 24VAC secondary
- 0-300 psi (0-20.7 bar) stainless steel solid state pressure transducer
- Overpressure indication

- Low Pressure indication
- Failed to start indication
- Main switch not in “Auto” alarm
- Pressure recording
- Event log (3000 events stored in controller memory)
- Data log (including cycle counter)
- Door mounted display/user interface featuring a 128 x 64 pixel backlit LCD Graphical Display, Membrane Type User Controller Push-buttons and LED indication for:
  - Power ON
  - Pump Running
  - Alarm
- 2 lines of user selectable display information

**NOTE:** FTA550F XG Jockey Pump Controllers are only available in the voltage/horsepower combinations shown below and with the options shown on the reverse side. For other combinations and options, see documentation for FTA550E series XG Jockey Pump Controllers.

	<b>VOLTAGE 3-PHASE (50/60 Hertz)</b>	<b>MAX HP (MCP)</b>	<b>Short Circuit Current Rating</b>
-H	200-208	7.5	30kA
-A	220-240	10	30kA
-F	380-415V - WYE	15	30kA
-B	440-480V - WYE	20	30kA
-C	550-600V - WYE	20	18kA

	<b>VOLTAGE 1-PHASE (50/60 Hertz)</b>	<b>MAX HP (MCP)</b>	<b>Short Circuit Current Rating</b>
-D	110-120 Volts	2	5kA
-T	200-208 Volts	3	5kA
-E	220-240 Volts	5	5kA

NOTE: Firetrol Brand Jockey Pump controllers DO NOT CONTAIN MERCURY filled pressure switches.

# FTA550F XG Jockey Pump Controllers Specifications

## Jockey Pump Controller

The auxiliary jockey pump controller, if required and specified on the plans and specifications, shall be factory assembled, wired, and tested and specifically designed for this type of service. This controller shall be of the same manufacturer as the main fire pump controller.

## Approvals

Firetrol Jockey Pump Controllers are listed by Underwriters Laboratories, Inc., in accordance with UL508A, Standard for Industrial Controls, and CSA, Standard for Industrial Control Equipment (cUL). They are built to meet or exceed the requirements of the approving authorities as well as NEMA and the latest edition of NFPA 70, National Electrical Code.

## Construction

The jockey pump controller shall be full voltage starting, rated for wye-connected power systems above 240V. The controller components shall be housed in a NEMA Type 2/12 (IEC IP22/IP54) polycarbonate, wall mounted enclosure (UL50E Construction). The controller shall incorporate a horsepower rated manual circuit protector and starting contactor, control circuit transformer with 24VAC secondary and 200-600V multi-tap primary, main disconnect switch, HAND-OFF-AUTOMATIC selector switch and a 0-300 psi (0-20.7 bar) stainless steel solid state pressure transducer.

## Short Circuit Current Ratings

The jockey shall have standard short circuit current ratings of:

30kA @ 480 Volts Max. (3-Phase)

18kA @ 600 Volts (3-Phase)

5kA @ 240 Volts Max. (1-Phase)

## Operator Interface

The jockey pump controller shall feature an operator interface with user keypad. The interface shall monitor and display motor operating conditions, including all alarms, events, and pressure conditions. The display shall be a 128x64 Backlit LCD capable of customized

graphics. The display and interface shall be NEMA rated for Type 2, 3R, 4, 4X, and 12 protection and shall be fully accessible without opening the controller door. The display and user interface shall utilize multiple levels of password protection for system security. A minimum of 3 password levels shall be provided. The operator shall have the ability to choose up to 2 lines of data to be displayed on the main (home) information screen.

## Digital Status/Alarm Messages

The digital display shall indicate text messages for the status and alarm conditions of:

- Pump Running
- Minimum Run Time
- Pump Restart Timer
- Automatic Start
- User Selectable #1<sup>1</sup>
- User Selectable #2<sup>1</sup>
- Sequential Start Time
- Low System Pressure
- Fail to Start
- System Overpressure
- Main Switch Position

<sup>1</sup> User may choose from the following to be shown on main display (stop pressure setting, start pressure setting, cycles/period, cycles/month, cycles/day, cycles/hour, total cycle count, pump total run time)

The Sequential Start Timer, Minimum Run Timer/Off Delay Timer and Pump Restart Timer shall be displayed as numeric values reflecting the value of the remaining time.

## LED Visual Indicators

LED indicators, visible with the door closed, shall indicate:

- Power ON
- Alarm
- Pump Running

## Data Logging

The digital display shall monitor the system and log the following data:

- Motor Calls/Starts
- Pump Last Run Time
- Last Pump Start
- Last Phase Fail/Reverse
- Pump Total Run Time
- Total Controller Pwr On Time
- Min/Max System Pressure
- Cycle Counts

### Event Recording

Memory - The controller shall record all operational and alarm events to system memory. All events shall be time and date stamped and include an index number. The system memory shall have the capability of storing 3000 events and allow the user access to the event log via the user interface. The user shall have the ability to scroll through the stored messages in groups of 1 or 10.

### Serial Communications

The controller shall feature a RS485 serial communications port for use with 2 or 4 wire Modbus communications.

### Solid State Pressure Transducer

The controller shall be supplied with a stainless steel solid state pressure transducer with a range of 0-300 psi (0-20.7 bar)  $\pm 1$  psi. The solid state pressure transducer shall be used for both display of the system pressure and control of the jockey pump controller. Systems using analog pressure devices or mercury switches for operational control will not be accepted.

The START and STOP PRESSURE shall be adjustable through the user interface. The pressure transducer shall be mounted inside the controller to prevent accidental damage. The pressure transducer shall be directly pipe mounted to a bulkhead pipe coupling without any other supporting members. Field connections shall be made externally at the controller coupling to prevent distortion of the pressure switch element and mechanism.

### Seismic Certification

The controller shall be certified to meet or exceed the requirements of the 2006 International Building Code and the 2010 California Building Code with Importance

Factor 1.5 and Sds equal to 1.88 or less. Qualifications shall be based upon successful tri-axial shake-table testing in accordance with ICC-ES AC-156. Certification without testing shall be unacceptable. Controller shall be clearly labeled as rated for installation in seismic areas and a Certificate of Conformance shall be provided with the controller.

### Operation

A digitally set On Delay (Sequential Start) timer shall be provided as standard. Upon a call to start, the user interface shall display a message indicating the remaining time value of the On Delay timer.

The controller shall include a Minimum Run Timer to allow the motor to run for a set period of timer after starting. The timer shall be programmable through the user interface.

A pump restart delay timer shall be provided to allow the residual voltage of the motor to decay prior to restarting the motor and to prevent severe short cycling of the motor. The timer shall be programmable through the user interface.

A Lamp Test feature shall be included. The user interface shall also have the ability to display the status of the system inputs and outputs.

An Audible Test feature shall be included to test the operation of the audible alarm device (if supplied).

The disconnect switch shall be mechanically interlocked so that the enclosure door cannot be opened with the handle in the ON position except by a hidden tool operated defeater mechanism. The disconnect switch shall be capable of being padlocked in the OFF position for installation and maintenance safety.

The controller shall be a Firetrol brand.

### Emerson Network Power - Global Headquarters

1050 Dearborn Drive  
Columbus, OH 43085  
Tel +1 614 888 0246

[EmersonNetworkPower.com](http://EmersonNetworkPower.com)

### ASCO Power Technologies - Firetrol Brand Products

111 Corning Road, Suite 120  
Cary, NC 27518  
Tel +1 919 460 5200 • Fax +1 919 460 5250

[Firetrol.com](http://Firetrol.com)

While every precaution has been taken to ensure accuracy and completeness herein, ASCO assumes no responsibility, and disclaims all liability, for damages resulting from use of this information or for any errors or omissions. Information and specifications are subject to change without notice. Emerson, Consider It Solved., Emerson Network Power, the Emerson Network Power Logo, ASCO, Firetrol and the Firetrol Logo are trademarks or registered trademarks of Emerson Electric Co. All other names and logos referred to are trade names, trademarks, or registered trademarks of their respective owners. ©2013 Emerson Electric Co. SP550F-01 (C)

**EMERSON. CONSIDER IT SOLVED.™**

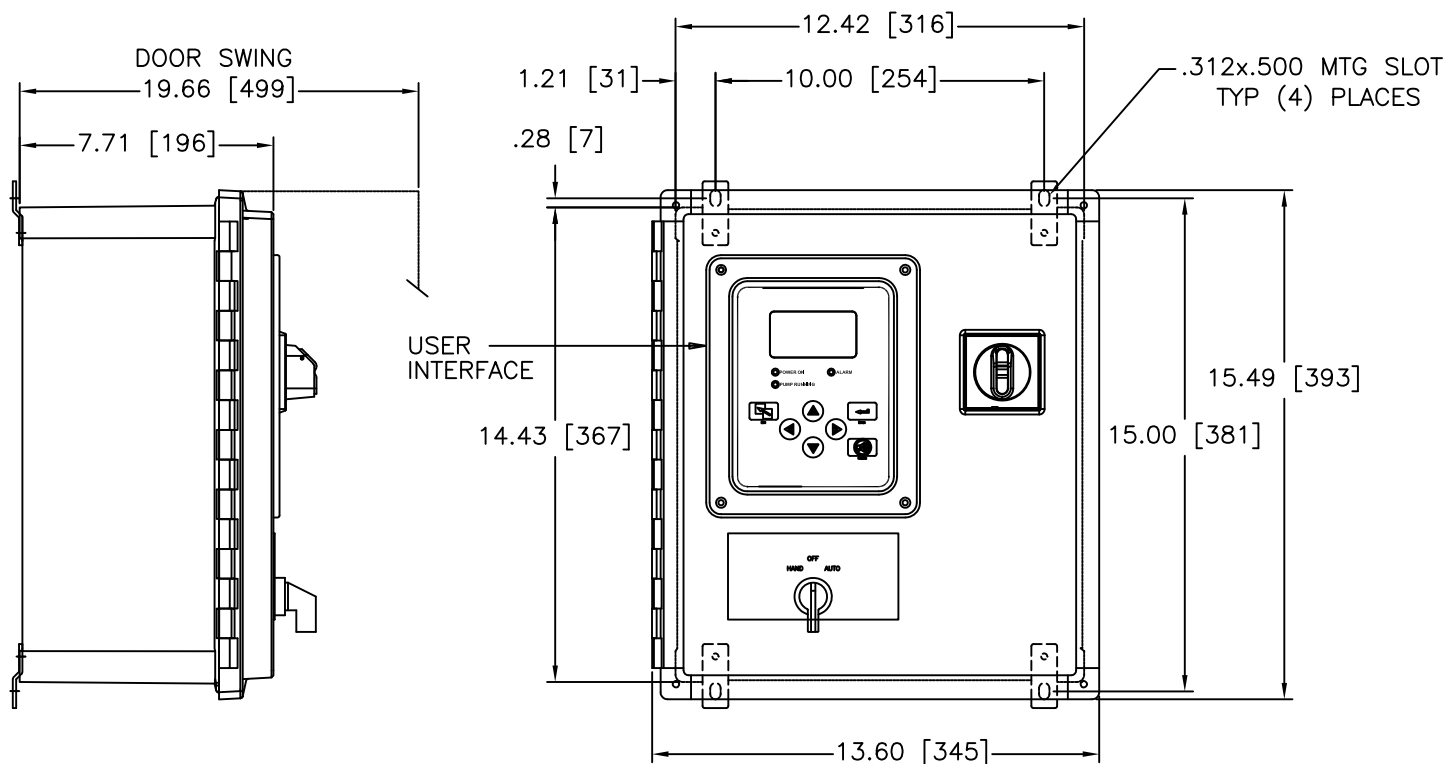

**NOTE**

CONDUIT ENTRANCE TOP AND BOTTOM ONLY DO NOT ENTER FROM SIDES.

**CAUTION**

BONDING BETWEEN CONDUIT CONNECTIONS IS NOT AUTOMATIC AND MUST BE PROVIDED AS PART OF THE INSTALLATION.

DIMENSIONS SHOWN ON THIS DRAWING ARE APPLICABLE FOR NEMA TYPES 2/3R/4/4X/12

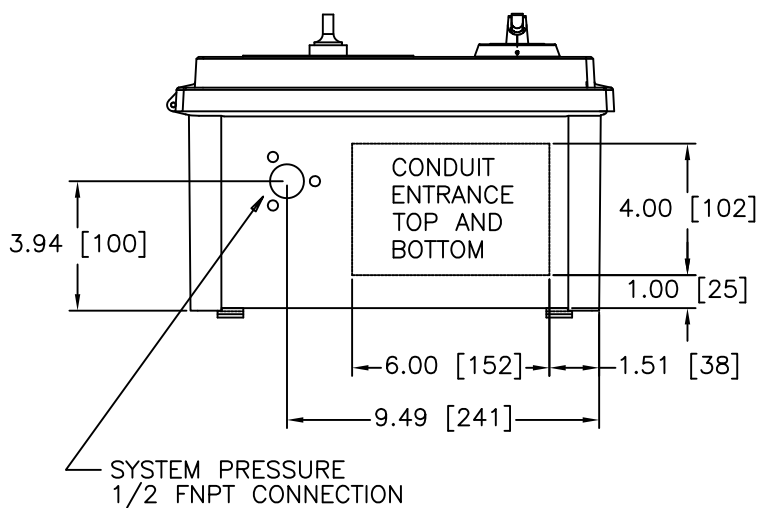

SHIPPING WEIGHT
APPROX. 15 [6.8]

MAXIMUM MOTOR HORSEPOWER				
200-208V	220-240V	380-415V	440-480V	550-600V
7 1/2	10	15	20	20

ALL DIMENSIONS - INCHES [MM]  
SHIPPING WEIGHT - POUNDS [KG]



PROJECT NAME:		REV. TO SHEET	ECN NO.	BY	APP.	DATE
Dimensions and Shipping Weight		FTA550F				
JOCKEY XG PUMP CONTROLLER (POLYCARBONATE)						THIRD ANGLE PROJECTION
BY		DATE	MANUFACTURING TOLERANCES TO BE IN ACCORDANCE WITH ASCO PROCEDURE MP-1-003. FOR PLASTIC PARTS SEE MP-1-055	ASSEM. REF. NO.		COMPUTER GENERATED DRAWING
DRAWN BY		TEF	02/29/12			SCALE 1:1 SIZE A
CHECKED						DWG. NO.
PROJECT APPROVAL						DD550-01
FINAL APPROVAL		TEF	02/29/12	ASCO POWER TECHNOLOGIES, L.P. FLORHAM PARK, NEW JERSEY 07932 U.S.A.		DRAWING REV. - ECN NO. 236029 SHEET 1 OF 1

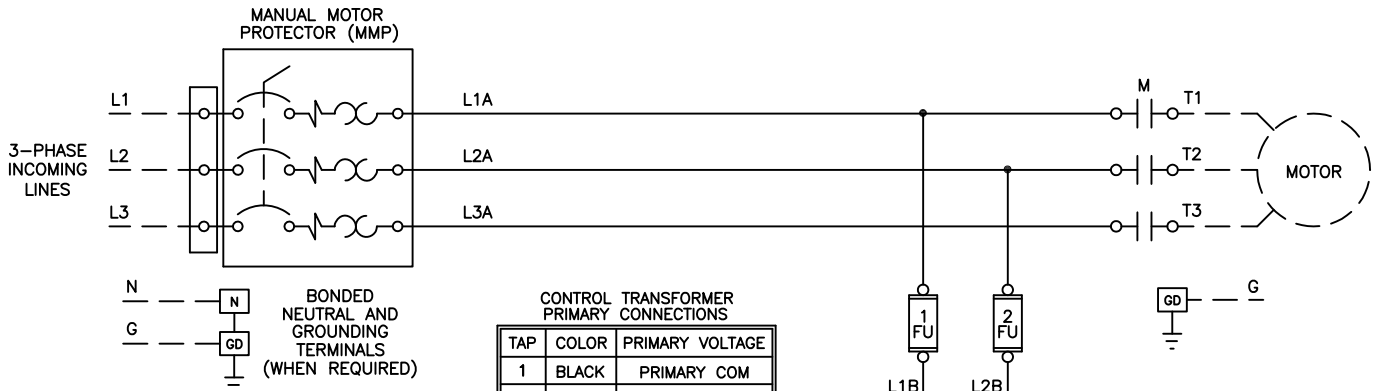

CONTROL TRANSFORMER PRIMARY CONNECTIONS

TAP	COLOR	PRIMARY VOLTAGE
1	BLACK	PRIMARY COM
2	BROWN	200-208VAC
3	YELLOW	220-240VAC
4	BLUE	380-415VAC
5	PURPLE	440-480VAC
6	GRAY	550-600VAC

**CAUTION**  
 BONDING BETWEEN CONDUIT CONNECTIONS IS NOT AUTOMATIC AND MUST BE PROVIDED AS PART OF THE INSTALLATION.

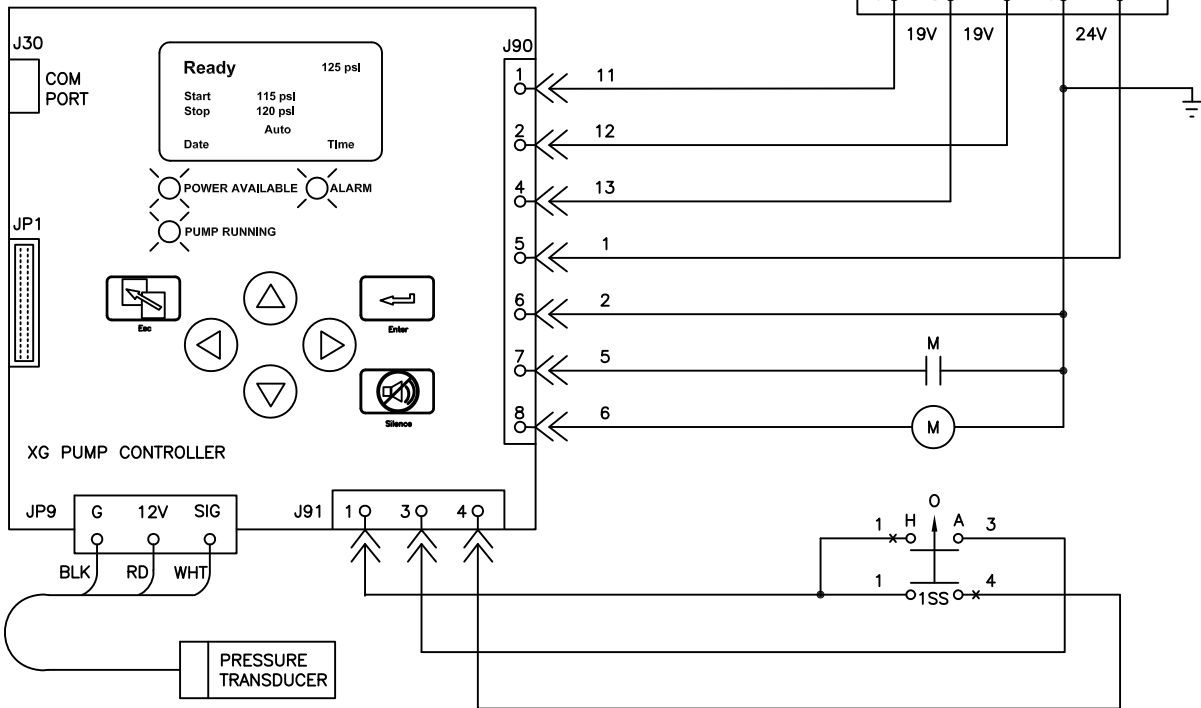

NEUTRAL AND GROUND TERMINALS WIRE CAPACITY (CU)

#14 AWG-#6 AWG  
 2.5 MM<sup>2</sup> -16 MM<sup>2</sup>

PRESSURE SYSTEM CONNECTION  
 1/2" FNPT

LINE TERMINALS-WIRE CAPACITY (CU) <sup>1</sup>

MAXIMUM MOTOR HORSEPOWER					WIRE SIZE COPPER ONLY
200-208V	220-240V	380-415V	440-480V	550-600V	
7 1/2	10	15	20	20	#10 AWG-#4 AWG 6 MM <sup>2</sup> -25 MM <sup>2</sup>

MOTOR TERMINALS-WIRE CAPACITY (CU) <sup>1</sup>

MAXIMUM MOTOR HORSEPOWER					WIRE SIZE COPPER ONLY
200-208V	220-240V	380-415V	440-480V	550-600V	
7 1/2	10	15	20	20	#14 AWG-#8 AWG 2.5 MM <sup>2</sup> -10 MM <sup>2</sup>

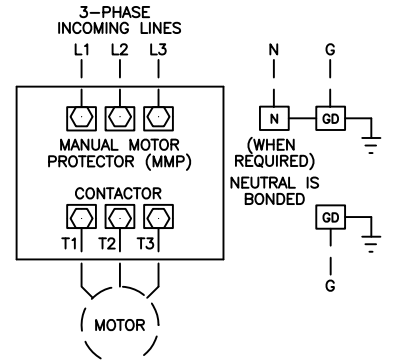

<sup>1</sup> FOR CORRECT WIRE SIZING, REFER TO NATIONAL ELECTRICAL CODE, NFPA 70.

PROJECT NAME:		REV. TO SHEET	EON NO.	BY	APP.	DATE
WIRING SCHEMATIC		FTA550F		THIRD ANGLE PROJECTION		
JOCKEY XG PUMP CONTROLLER WITH MANUAL MOTOR PROTECTOR						
DRAWN BY	TEF	DATE	02/27/12	MANUFACTURING TOLERANCES TO BE IN ACCORDANCE WITH ASCO PROCEDURE MP-1-003. FOR PLASTIC PARTS SEE MP-1-055		ASSEM. REF. NO.
CHECKED				PROPERTY OF ASCO POWER TECHNOLOGIES. USE PERMITTED FOR OUR WORK ONLY. ALL RIGHTS OF DESIGN OR INVENTION ARE RESERVED.		SCALE 1:1 SIZE A
PROJECT APPROVAL				ASCO <sup>®</sup> ASCO POWER TECHNOLOGIES, L.P. FLORHAM PARK, NEW JERSEY 07932 U.S.A.		DWG. NO. WS550-01
FINAL APPROVAL	TEF	DATE	02/29/12			DRAWING REV. - EON NO. 236029 SHEET 1 OF 1



- MODIFICATION J - SPACE HEATER, 110-120VAC (WITH THERMOSTAT)
- MODIFICATION M - SPACE HEATER, 220-240VAC (WITH THERMOSTAT)

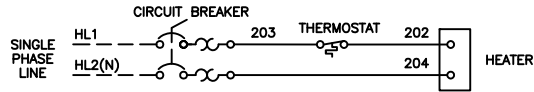

- MODIFICATION K - SPACE HEATER, 110-120VAC (WITH HUMIDISTAT)
- MODIFICATION N - SPACE HEATER, 220-240VAC (WITH HUMIDISTAT)

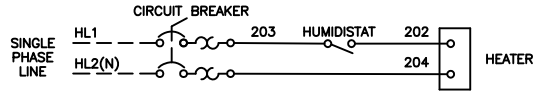

- MODIFICATION AC - PUMP OPERATING ALARM CONTACTS

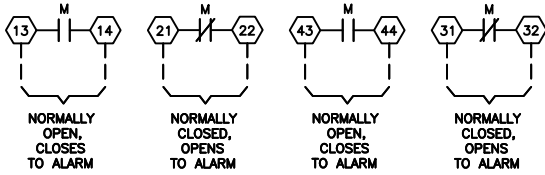

○ - TERMINALS LOCATED ON CONTACTOR (M)

- MODIFICATION BY - PUMP OVERLOAD REMOTE ALARM CONTACT

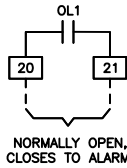

- MODIFICATION NZ - INTERLOCK SHUTDOWN IN AUTO

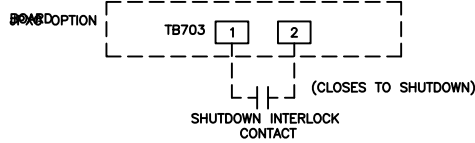

- MODIFICATION AST - REMOTE AUTO START INPUT

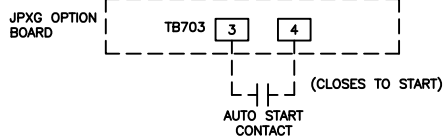

WIRING REQUIRED WHEN JPXG OPTION BOARD IS USED

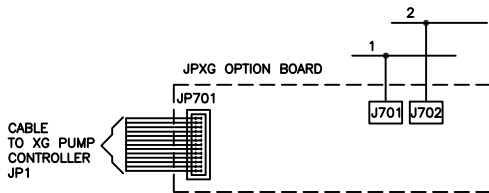

- MODIFICATION AM - PUMP FAILED TO START REMOTE ALARM CONTACTS

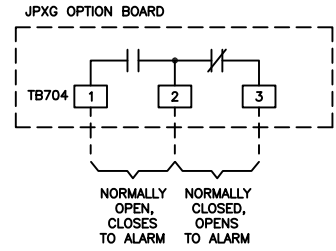

- MODIFICATION EF - SWITCH NOT IN AUTO REMOTE ALARM CONTACTS

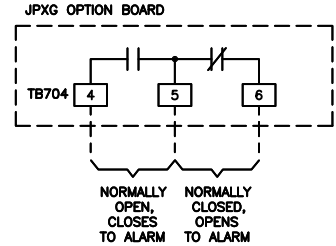

- MODIFICATION KH - COMMON TROUBLE REMOTE ALARM CONTACTS

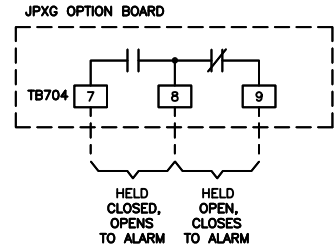

- MODIFICATION BW - PHASE FAILURE/REVERSAL REMOTE ALARM CONTACTS

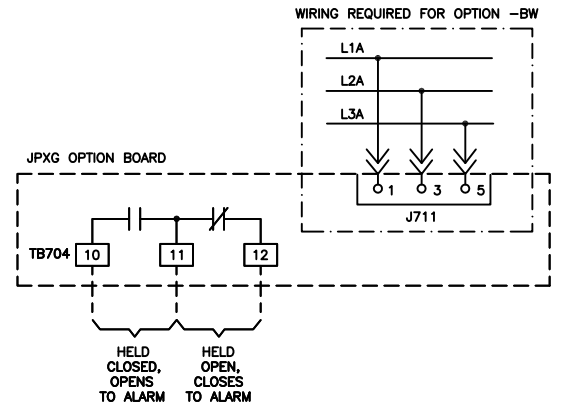

CONTROL AND ALARM TERMINAL WIRE CAPACITY	
JPXG OPTION BOARD TERMINALS	#18-12 AWG [.75-4 MM <sup>2</sup> ]
PUMP OPERATING TERMINALS	#18-14 AWG [.75-2.5 MM <sup>2</sup> ]
CIRCUIT BREAKERS	#14-4 AWG [2.5-25 MM <sup>2</sup> ]

PROJECT NAME:		REV. TO SHEET	ECN NO.	BY	APP.	DATE
WIRING SCHEMATIC		FTA550F		 THIRD ANGLE PROJECTION		
JOCKEY XG PUMP CONTROLLER WITH MANUAL MOTOR PROTECTOR						
OPTIONS AND MODIFICATIONS						
DRAWN BY	TEF	DATE	02/27/12	MANUFACTURING TOLERANCES TO BE IN ACCORDANCE WITH ASCO PROCEDURE MP-1-003. FOR PLASTIC PARTS SEE MP-1-055	ASSEM. REF. NO.	COMPUTER GENERATED DRAWING
CHECKED				PROPERTY OF ASCO POWER TECHNOLOGIES. USE PERMITTED FOR OUR WORK ONLY. ALL RIGHTS OF DESIGN OR INVENTION ARE RESERVED.	SCALE	1:1 SIZE A
PROJECT APPROVAL					DWG. NO.	WS550-02
FINAL APPROVAL	TEF	DATE	02/29/12	ASCO <sup>®</sup> ASCO POWER TECHNOLOGIES, L.P. FLORHAM PARK, NEW JERSEY 07932 U.S.A.	DRAWING REV.	ECN NO. 236029 SHEET 1 OF 1

